

External view

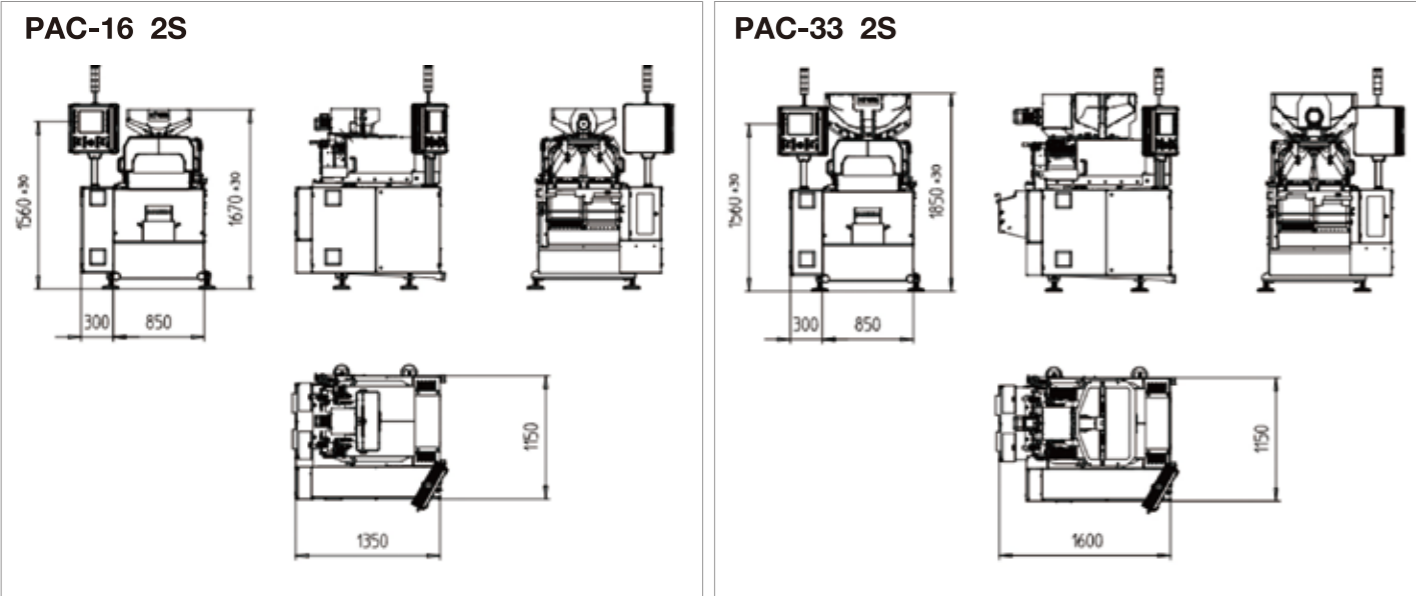

MACHINE TYPE	PAC-16 2S	PAC-33 2S
PRODUCT RANGE	M6 – M16	M14 – M33
MAX PRODUCT DIMENSION	34 mm	65 mm
BENT SHANK CONFIG	245 x 30 x 40	480 x 65 x 80
TAP LENGTH x R x H	280 x 30 x 40 375 x 45 x 52	520 x 65 x 75
MAX OUTPUT (PCS / h) <small>(depending on material and tools)</small>	6000	3200
SPINDLE TYPE	Brushless DC motor constant torque	
	0 – 3000 rpm	0 – 1050 rpm
NUT PUSHER TYPE	Brushless DC motor (adjustable speed and force)	
TOTAL INSTALL POWER	5,5 Kw – 400 V	8,0Kw – 400V
TOTAL WEIGHT (EMPTY)	1100 kg	1700kg
TANK CAPACITY	200 l	250 l

»» TRY

TRY YOUR PRODUCT ON
PAC-16 AVAILABLE FOR YOU
AT OUR TEST ROOM

NIPPON TAPPER Co.,Ltd
13-10 5-CHOME OMORIHIGASHI
OTA-KU TOKYO 1430012 JAPAN
TEL +81 3 6404 9110
FAX +81 3 6404 9111
E-meil info@nippon-tapper.co.jp
www.nippon-tapper.co.jp

To achieve the best nut tapping quality you need our

PERFECT
AUTO
CONTROL

Patent # 7042267

High speed tapping machine
PAC series



To achieve the best nut tapping quality you need our

PERFECT AUTO CONTROL

> PERFECT

TAP RUNOUT FREE

Part of PAC series is special patent system named **FCT** - First Class Tapping - that guarantees an **accurate centralization** of taps during tapping process of **EACH individual nut** Patent



> AUTOMATIC

ALL AXIS BRUSHLESS CONTROLLED

PAC series machines manage **all tapping movements** through special servo-cylinders managed by PLC, with accurate adjustments of all speeds and torques Patent

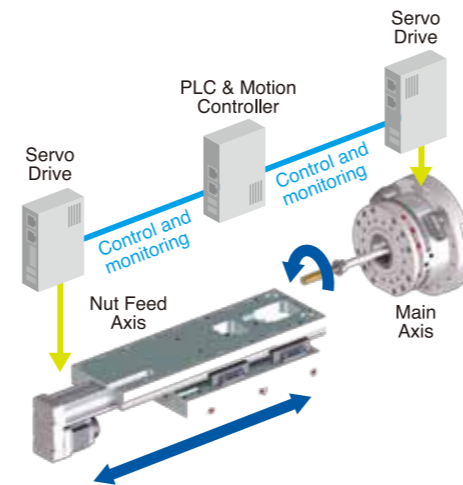

Part of PAC series is special patent system named **SMF** - Spindle Maintenance Free - that guarantees an **accurate spindle** adjustments thanks its special spindle concept with NO transmission that also does it means NO maintenance Patent pending

> CONTROL

100% PRODUCTS TORQUE DETECTION

PAC machine series has a specific setting adjustment from PLC and just in time 10" display visualization regarding **torque tolerances and graph** of both spindles

PAC machine series has an **accurate diagnostics system** to immediately detect product or process problems

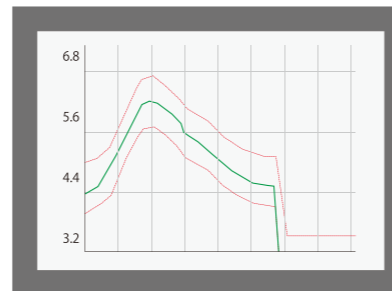

Individual torque tolerances and graph

MEANS FOR YOU

100% NUTS QUALITY UNDER CONTROL



+



TAPS LONGER LIFE

PAC MACHINE ADVANTAGE

- > PAC machines series can work **all kind of pierced products** (hexagonal, square nuts, round products) for all kind of materials (soft like Aluminium or hard like product after heat treatment)
- > PAC machines series can work with **standard customer taps length**
- > PAC special option can send all production data and report **automatically to computer manager**
- > PAC special option is **automatic scrap chute** during startup of new batch
- > PAC machine as **very compact layout** for space saving in your building
- > PAC series machines are energy saver -20% less compared with a traditional tapping machine

